

Basi statiche di bloccaggio, pneumatiche-idrauliche, autocentranti - CFB
Clamping force blocks, pneumatic-hydraulic, centric clamping - CFB
Kraftspannblock, pneumatisch-hydraulisch, zentrisch spannend - CFB
Étaux de serrage, pneumatique-hydraulique, autocentres - CFB



Dati tecnici

- Pressione d'esercizio: 9 bar con aria (6 bar per CFB 250) max 60 bar con olio
- Precisione di reperibilità: CFB 66... 100 0.01 mm
CFB 160...200 0.02 mm
CFB 250 0.03 mm su 100 cicli
- Temperatura d'esercizio: da 5°C a 60°C
- Sistema di funzionamento: cinematica a piani inclinati con guida forzata e trasmissione della forza applicata alle superfici
- Corsa totale dei carrellini da 4 a 30 mm
- Applicazione tramite: fori per spine H7
- Materiale corpo: acciaio trattato
- Materiale parti funzionali: acciaio trattato
- Funzionamento: olio filtrato (10µm) viscosità 46 mm²/s a 40° ISO VG; max 60° aria compressa filtrata (10µm) e lubrificata
- attacchi: laterali-base
- manutenzione: lubrificare 100.000 cicli con presa di manipolazione ogni 5.000 cicli per presa in lavorazione

Technische Daten

- Betriebsdruck: max 9 bar (6 bar bei CFB 250) in der pneumatischen Version; max 60 bar in der hydraulischen Version
- Wiederholgenauigkeit: CFB 66... 100 0.01 mm
CFB 160...200 0.02 mm
CFB 250 0.03 mm über Schaltspiele
- Betriebstemperaturbereich: von 5°C bis 60°C
- Wirkprinzip: Keilhakenprinzip zwangsgeführt über schräge Ebene
- Parallel Öffnen/Schliessen, Gesamthub der Schlitten 2 bis 30 mm
- Ausrichten der Gehäuse durch Verstiftung H7
- Gehäusematerial: aus gehärtetem Stahl
- Funktionsteile: aus gehärtetem Stahl
- Betätigung: hydraulisch über gefiltertes Öl (10µm), Viskosität 46 mm²/s bei 40°C ISO VG; maximal 60°C, pneumatisch über gefilterte Druckluft (10µm) und geölt
- Schmierintervall bei Einsatz auf Zerspanungsmaschine alle 5.000 Schaltspiele bei Handhabungsprozessen alle 100.000 Schaltspiele

Technical data

- Operating pressure range: 9 bar with air (6 bar per CFB 250) max 60 bar with oil
- Repeatability accuracy: CFB 66... 100 0.01 mm
CFB 160...200 0.02 mm
CFB 250 0.03 mm over 100 cycles
- Operating temperature range: from 5°C to 60°C
- Operating principle: wedge and piston design with mechanically restricted guidance
- Stroke range from 4 to 30 mm
- Mounting: by means of bores for H7 pins
- Housing material: hardened steel
- Material for functional parts: hardened steel
- Actuation: filtered hydraulic oil (10µm) viscosity 46 mm²/s at 40° ISO VG; max 60° compressed air (10µm) and lubricated
- Connections: sides-base
- Maintenance: relubricated every 10.000 cycles when used in handling. When used in machining centers for tool clamping, lubricate every 5.000 cycles

Données techniques

- Pressione de service: max 9 bar en pneumatique aria (6 bar pour CFB 250) max 60 bar en hydraulique
- Précision de répétabilité: CFB 66... 100 0.01 mm
CFB 160...200 0.02 mm
CFB 250 0.03 mm sur 100 cycles
- Température de service: de 5°C à 60°C
- Système de fonctionnement: piston et noix de commande à rampe
- Course parallèle des mors élevée de 2 à 30 mm
- Centrage par: trous pour goupilles H7
- Matière du corps: en Acier trempé
- Matière des pièces fonctionnelles: en Acier trempé
- Fonctionnement: huile filtré (10µm) viscosité 46 mm²/s à 40° ISO VG; max 60° air filtré (10µm) et lubrifié
- Conduites: sur le coté - sur la base
- Maintenance: lubrification tous les 5.000 cycles avec serrage de pièces à usiner les 100.000 cycles avec serrage de manipulation

Basi statiche di bloccaggio, pneumatiche-idrauliche, autocentranti - CFB
Clamping force blocks, pneumatic-hydraulic, centric clamping - CFB
Kraftspannblock, pneumatisch-hydraulisch, zentrisch spannend - CFB
Étaux de serrage, pneumatique-hydraulique, autocentres - CFB

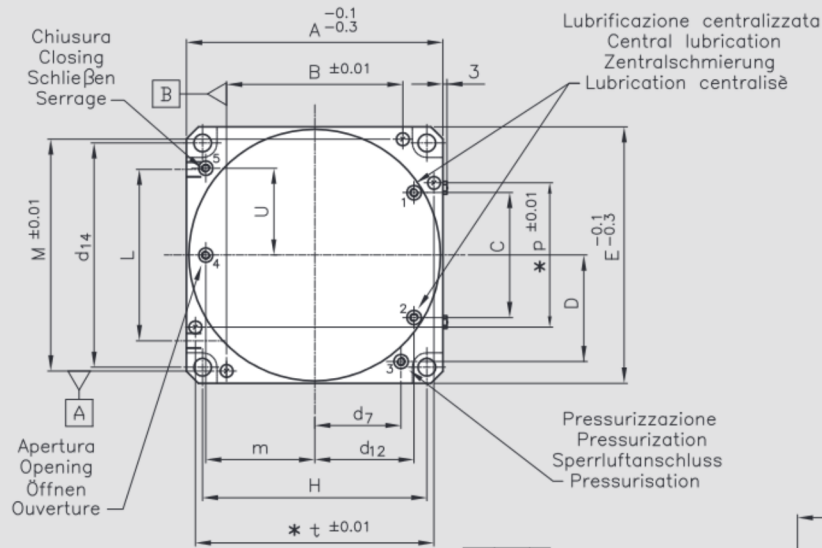

Version Z
N ± 0,01
to clamping center
J ± 0,01

PNEUMATIC

*On request

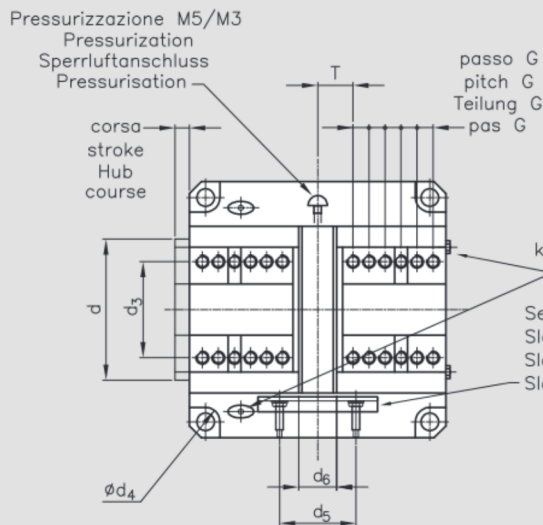
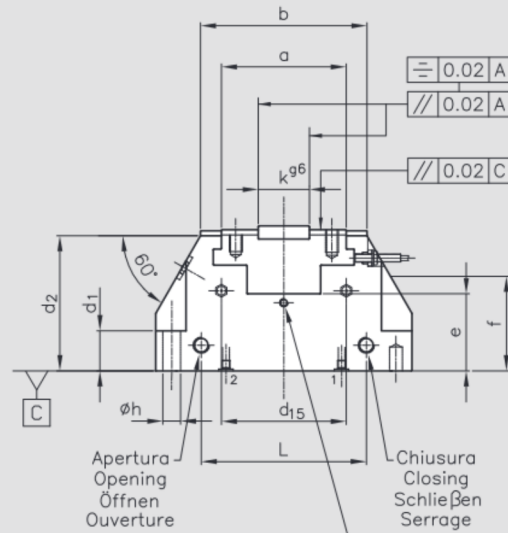
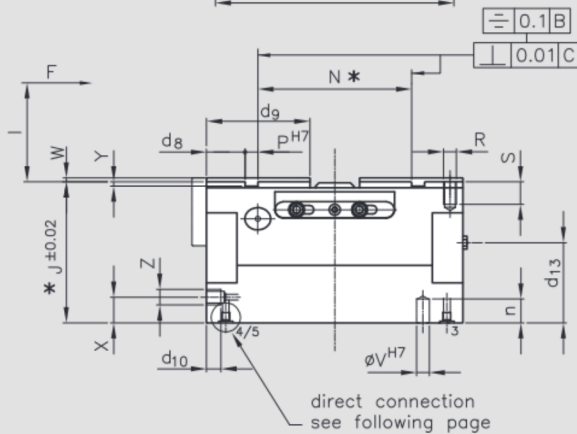

Ingrassatori DIN 3405 AM6
 Grease fittings DIN 3405 AM6
 kegelschmiernippel DIN 3405 AM6
 Graisseur DIN 3405 AM6

Sede per sensori induttivi d₁₁
 Slot for inductive proximity switches d₁₁
 Slot für induktive Näherungsschalter d₁₁
 Slot pour détecteur de proximité inductifs d₁₁

PNEUMATIC																						
Type	A	B	C	D	E	G	H	L	M	P	R	S	U	V	Z	X	Y	W	J	K	a	b
CFB 66	66	42	34	29.5	66	5x3	54	37	59	4	M4	6.5	18.5	4	M5	15	2.7	1.8	53	14	30	43
CFB 100	102	64	50	45	102	7x4	80	63	90	6	M6	9	31	6	M5	20	2.7	1.8	71.5	20	47	66
CFB 160	160	110	78	55	160	10x5	140	103	140	8	M8	13	51.5	8	1/8	16	3.2	1.8	88.5	32	78	104
CFB 200	200	130	106	65	200	10x7	164	128	186	8	M8	13	64	8	1/8	18	4	2.3	93.5	40	102	140
CFB 250	254	156	124	79	254	12x7	202	159	232	10	M10	18	79.5	10	1/8	18	4	2.3	103	50	125	170

Type	d	d ₁	d ₂	d ₃	d ₄	d ₅	d ₆	d ₇	d ₉	d ₁₀	d ₁₁	d ₁₂	d ₁₃	d ₁₄	d ₁₅	e	f	Vers. 1			Vers. 2			p	t
Type	d	d ₁	d ₂	d ₃	d ₄	d ₅	d ₆	d ₇	d ₉	d ₁₀	d ₁₁	d ₁₂	d ₁₃	d ₁₄	d ₁₅	e	f	T	N	d ₈	T	N	d ₈	p	t
CFB 66	38	26	49.5	24	11	/	12	19.5	26.3	6	/	23	16	54	34	30	/	10.2	26.4	15.8	/	/	/	40	59
CFB 100	58	34	68	35	13.5	40	19	31	41	6	M5	37	15	80	51	38	55.7	14.5	51	19.5	15	52	19	66	93
CFB 160	91	25	84.8	60	18	48	24	70	67.5	9	M5	62	49.5	140	78	47.5	71	18.8	89.6	27.2	19	90	27	81	149
CFB 200	118	35	89.5	74	19	65	27	87	85.5	9	M8	91.5	54	164	106	51	74	20	92	46	20	92	46	149	186
CFB 250	142	45	98.8	90	19	86	35	109	108.5	9	M8	119	58	202	124	55	81	32.5	103	65.5	25	112	61	182	225

Tipo					Versione	Forza di serraggio (N)	Pressione (bars)	Corsa per griffa (mm)	Lung. Max griffa	Tempo circa (s) apertura chiusura	Consumo olio per doppia corsa (cm ³)	Massa (Kg)
Type					Version	Clamping force in N	Pressure (bars)	Stroke for jaw (mm)	Max top jaw lenght	Approx. Time (s) opening closing	Air consumption for double stroke (cm ³)	Wise weight (Kg)
Typ					Version	Spannkraft (N)	Druck (bars)	Hub pro Finger (mm)	Max Fingerlänge	Schließzeit (s) öffnen schließen	Fluidverbrauch pro Doppelhub (cm ³)	Eigenmasse (Kg)
Type	h	l	m	n	Version	Force de serrage (N)	Pression (bars)	Course par morse (mm)	Max longueur des mors	Temp environ (s) ouverture serrage	Consommation huile pour double course (cm ³)	Masse (Kg)
CFB 66	6.5	10	21	7.5	1	4.500	9	2	60	0.1	0.1	1.5
CFB 100	8.5	16	31.5	12	1	7.600	9	6	150	0.2	0.2	4.5
					2	19.000		2	60			
CFB 160	11	25	52	14	1	20.000	9	8	200	0.4	0.4	14
					2	48.000		3	60			
CFB 200	13	32	66	14	1	22.000	9	10	280	0.85	0.85	23
					2	52.000		4	105			
CFB 250	13	40	88.5	18	1	22.000	6	15	500	1	1	35
					2	55.000		5	150			

- La forza di serraggio è la somma aritmetica delle forze individuali create alle griffe a "l" mm di distanza a 6/9 bar. I tempi di apertura e chiusura sono puramente i tempi che le griffe o morsetti sono in movimento.
- The gripping force is the arithmetic sum of the individual forces created at the fingers at "l" mm distance at 6/9 bar. Closing and opening times are purely the times that the base jaw or fingers are in motion.
- Die Greifkraft ist die arithmetische Summe der an den Greifbacken auftretenden Einzelkräfte im Abstand "l" mm. Schließ- und Öffnungszeiten sind reine Rotationszeiten, dass die Grundbacken oder Finger in Bewegung sind.
- La force de serrage est la somme arithmétique des forces individuelles créées dans les mors à "l" mm distance. Serrage et temps d'ouverture sont les temps que le mors de base ou des doigts sont en mouvement.

Conessioni dirette senza tubi Hose-free direct connection

Maße für schlauchlosen Direktanschluss Connexion directe sans tuyaux

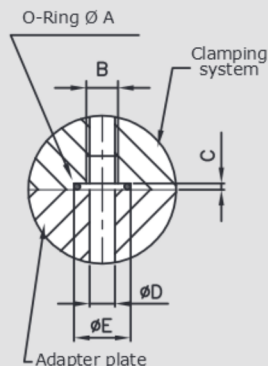

Type	Hole 4 and 5 Funzionamento Actuation Betaetigung Fontionnement					Hole 3 Pressurizzazione Pressurization Sperrluftanschluss Pressurisation					Hole 1 and 2 Lubrificazione centralizzata Central lubrication Zentralschmierung Lubrication centralisé				
	A	B	C	D	E	A	B	C	D	E	A	B	C	D	E
CFB 66	Ø4x1	M3	0.7	2.5	6	Ø3.5x1	M3	0.7	2.5	5.5	Ø3.5x1	M3	0.7	2.5	5.5
CFB 100	Ø6x1.5	M5	1	4	9	Ø5x1.5	M4	1	3.5	8	Ø5x1.5	M4	1	3.5	8
CFB 160	Ø6x1.5	M5	1	4	9	Ø5x1.5	M4	1	3.5	8	Ø5x1.5	M4	1	3.5	8
CFB 200	Ø7x1.5	M6	1	5	10	Ø6x1.5	M5	1	4	9	Ø6x1.5	M5	1	4	9
CFB 250	Ø7x1.5	M6	1	5	10	Ø6x1.5	M5	1	4	9	Ø6x1.5	M5	1	4	9

Basi statiche di bloccaggio, pneumatiche-idrauliche, autocentranti - CFB
Clamping force blocks, pneumatic-hydraulic, centric clamping - CFB
Kraftspannblock, pneumatisch-hydraulisch, zentrisch spannend - CFB
Étaux de serrage, pneumatique-hydraulique, autocentreurs - CFB

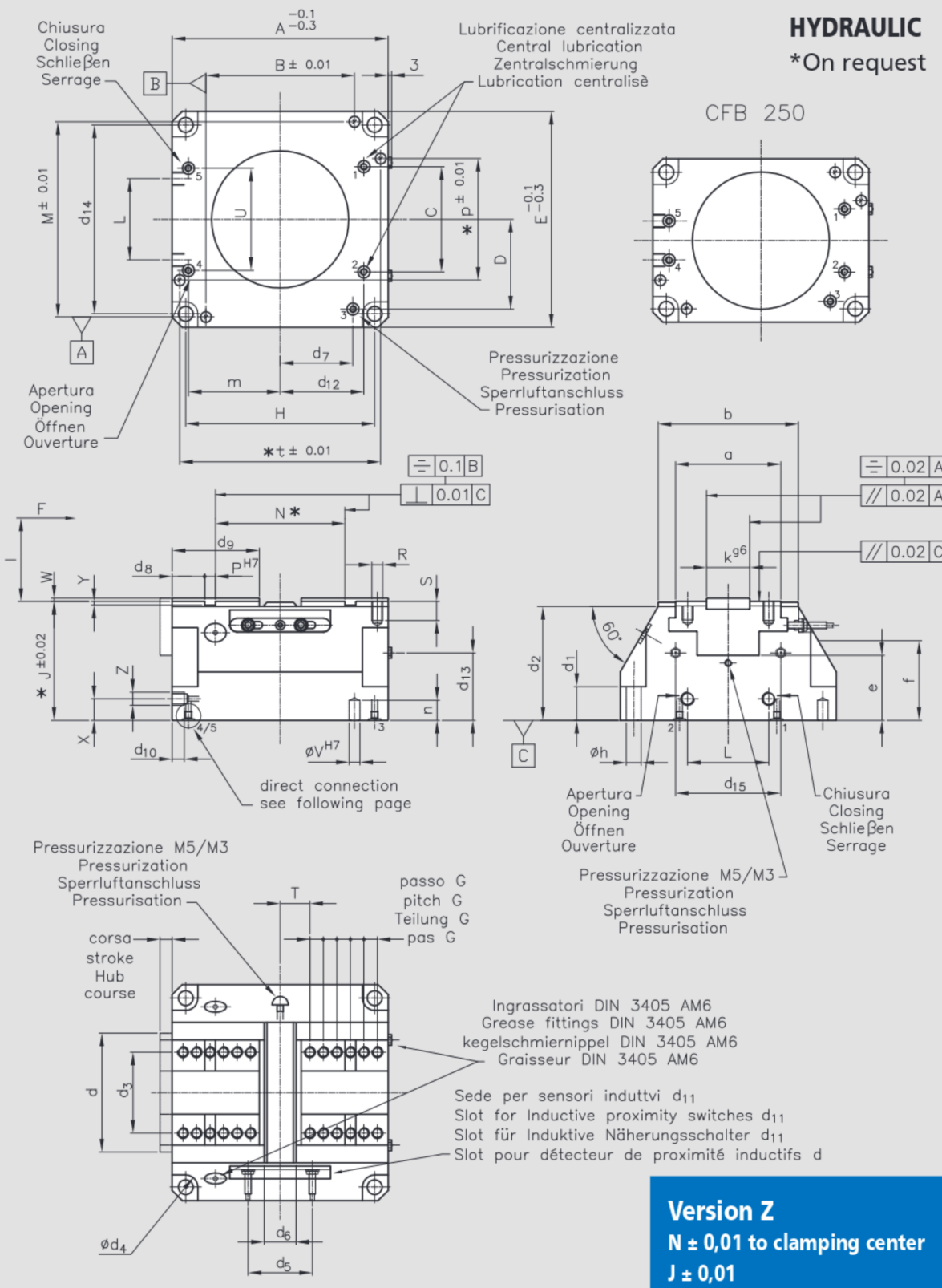

HYDRAULIC

Type	A	B	C	D	E	G	H	L	M	P	R	S	U	V	Z	X	Y	W	J	K	a	b
CFB66	66	42	34	28	66	5x3	54	27	59	4	M4	6.5	35	4	1/8	15	2.7	1.8	53	14	30	43
CFB 100	102	64	51	44.5	102	7x4	80	34	90	6	M6	9	34	6	1/8	20	2.7	1.8	71.5	20	47	66
CFB 160	160	110	78	55	160	10x5	140	42	140	8	M8	13	42	8	1/8	16	3.2	1.8	88.5	32	78	104
CFB 200	200	130	106	65	200	10x7	164	70	186	8	M8	13	70	8	1/8	18	4	2.3	93.5	40	102	140
CFB 250	254	156	124	79	210	12x7	202	96	189	10	M10	18	96	10	1/8	18	4	2.3	103	50	125	170

Type	d	d ₁	d ₂	d ₃	d ₄	d ₅	d ₆	d ₇	d ₉	d ₁₀	d ₁₁	d ₁₂	d ₁₃	d ₁₄	d ₁₅	e	f	Vers. 1			Vers. 2			p	t
																		T	N	d ₈	T	N	d ₈		
CFB66	38	26	49.5	24	11	/	12	19	26.3	8	/	25	16	54	34	30	/	10.2	26.4	15.8	/	/	/	20	59
CFB 100	58	34	68	35	13.5	40	19	31	41	8	M5	37.2	15	80	51	38	55.7	14.5	51	19.5	15	52	19	66	93
CFB 160	91	25	84.8	60	18	48	24	70	67.5	9	M5	62	49.5	140	78	47.5	71	18.8	89.6	27.2	19	90	27	81	149
CFB 200	118	35	89.5	74	19	65	27	87	85.5	9	M8	91.5	54	164	106	51	74	20	92	46	/	/	/	149	186
CFB 250	142	45	98.8	90	19	86	35	109	108.5	9	M8	119	58	189	124	55	81	32.5	103	65.5	/	/	/	169	225

Tipo					Versione	Forza di serraggio (N)	Pressione (bars)	Corsa per griffa (mm)	Lungh. Max griffa	Tempo circa (s)		Consumo olio per doppia corsa (cm ³)	Massa (Kg)	
Type					Version	Clamping force in N	Pressure (bars)	Stroke for jaw (mm)	Max top jaw lenght	Approx. Time (s)	opening	closing	Air consumption for double stroke (cm ³)	Vise weight (Kg)
Typ					Version	Spannkraft (N)	Druck (bars)	Hub pro Finger (mm)	Max Fingerlänge	Schließzeit (s)		Fluidverbrauch pro Doppelhub (cm ³)	Eigenmasse (Kg)	
Type	h	l	m	n	Version	Force de serrage (N)	Pression (bars)	Course par morse (mm)	Max longueur des mors	Temp environ (s)		Consommation huile pour double course (cm ³)	Masse (Kg)	
										ouverture	serrage			
CFB 66	6.5	10	25	7.5	1	6.800	60	2	60	0.5	0.5	10	1.5	
CFB 100	8.5	16	40	12	1	16.000	120	6	60	1	1	33	4.9	
					2	20.000	60	2						
CFB 160	11	25	68	14	1	44.000	120	8	60	1.5	1.5	105	14.5	
					2	54.000	60	3						
CFB 200	13	32	88	14	1	56.000	60	10	95	2.3	2.3	240	24	
CFB 250	13	40	115	18	1	62.000	60	15	140	3	3	440	37	

- La forza di serraggio è la somma aritmetica delle forze individuali create alle griffe a "l" mm di distanza a 60/120 bar. I tempi di apertura e chiusura sono puramente i tempi che le griffe o morsetti sono in movimento.
- The gripping force is the arithmetic sum of the individual forces created at the fingers at "l" mm distance at 60/120 bar. Closing and opening times are purely the times that the base jaw or fingers are in motion.
- Die Greifkraft ist die arithmetische Summe der an den Greifbacken auftretenden Einzelkräfte im Abstand "l" mm bei 60/120 bar. Schließ- und Öffnungszeiten sind reine Rotationszeiten, dass die Grundbacken oder Finger in Bewegung sind.
- La force de serrage est la somme arithmétique des forces individuelles créées dans les mors à "l" mm distance à 60/120 bar. Serrage et temps d'ouverture sont les temps que le mors de base ou des doigts sont en mouvement.

Conessioni dirette senza tubi Hose-free direct connection

Maße für schlauchlosen Direktanschluss Connexion directe sans tuyaux

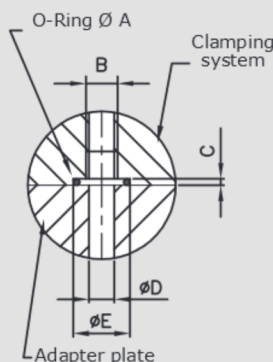

Type	Hole 4 & 5 Funzionamento Actuation Betaetigung Fontionement					Hole 3 Pressurizzazione Pressurization Sperrluftanschluss Pressurisation					Hole 1 & 2 Lubrificazione centralizzata Central lubrication Zentralschmierung Lubrication centralisé				
	A	B	C	D	E	A	B	C	D	E	A	B	C	D	E
CFB 66	Ø5x1.5	M4	1	3.5	8	Ø2.5x1.5	M3	1	2.5	5.5	Ø2.5x1.5	M3	1	2.5	5.5
CFB 100	Ø6x1.5	M5	1	4	9	Ø5x1.5	M4	1	3.5	8	Ø5x1.5	M4	1	3.5	8
CFB 160	Ø7x1.5	M6	1	5	10	Ø5x1.5	M4	1	3.5	8	Ø5x1.5	M4	1	3.5	8
CFB 200	Ø7x1.5	M6	1	5	10	Ø6x1.5	M5	1	4	9	Ø6x1.5	M5	1	4	9
CFB 250	Ø7x1.5	M6	1	5	10	Ø6x1.5	M5	1	4	9	Ø6x1.5	M5	1	4	9

Basi statiche di bloccaggio, pneumatiche-idrauliche, autocentranti - CFB
Clamping force blocks, pneumatic-hydraulic, centric clamping - CFB
Kraftspannblock, pneumatisch-hydraulisch, zentrisch spannend - CFB
Étaux de serrage, pneumatique-hydraulique, autocentres - CFB

Centraggio - codice BC
Centering - code BC

Zentrier - Code BC
Centrage - code BC

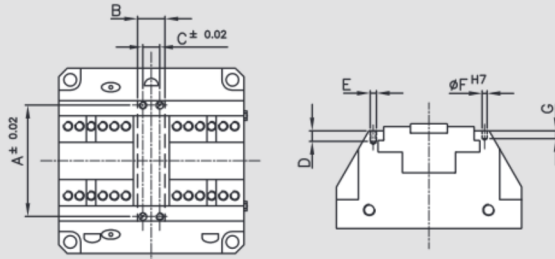

Code	A	B	C	D	E	F	G
CFB 66	37.4	12	5	4	M2.5	3	3
CFB 100	58	19	9	5	M3	4	4
CFB 160	94	23.6	10	7	M4	5	7
CFB 200	126	27	12	9	M5	5	7
CFB 250	155	35	14	12	M6	6	9

Versione con griffe dentate - Cod. D
Version with serrated fingers - code D

Mit Spitzverzahnung - Version D
Version à morse striées - code D

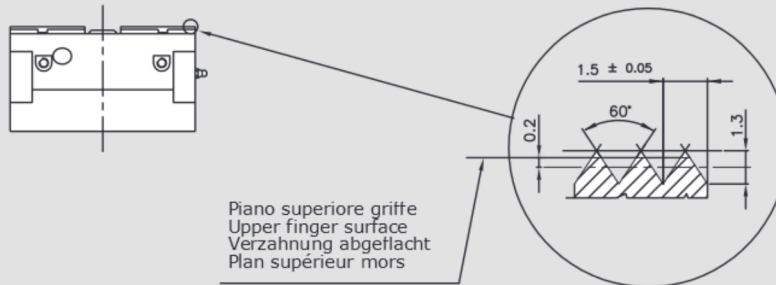

Dati di carico
Load data

Lastdaten
Données de charge

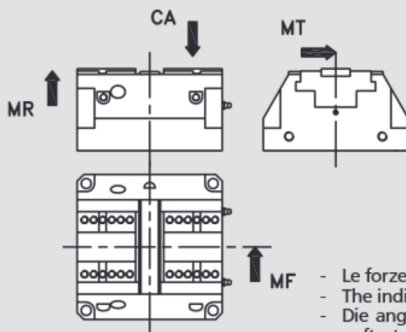

Type	CA (N)	MR (Nm)	MF (Nm)	MT (Nm)
CFB 66	2000	75	75	75
CFB 100	5000	250	250	250
CFB 160	10000	500	500	500
CFB 200	13500	800	800	800
CFB 250	22000	1200	1200	1200

- Le forze e i momenti indicati sono valori statici applicati per griffa e possono occorrere simultaneamente.
- The indicated force and moment are static values apply for base jaw and may occur simultaneously.
- Die angegebenen Kräfte und Momente sind statische Werte, gelten je Grundbacke und dürfen gleichzeitig auftreten.
- La force et le moment indiqués valeurs statiques sont valables pour mors de base et peuvent se produire simultanément.

Esempio d'ordine - Ordering data

Bestellbeispiel - Exemple de commande

Tipo	Versione 1 o 2	Indicare PN per vers. pneumatica e ID per vers. idraulica	Kit per montare sensori induttivi - indicare S	Per centraggio indicare cod. BC	Griffe dentate cod. D	Versione ±0.01 indicare Z
Type	Version 1 or 2	Indicate for pneumatic PN and for hydraulic ID	Kit to mount Inductive proximity switches - indicate code S	For centering indicate BC	Serrated fingers code D	Version ±0.01 Code Z
Typ	Version 1 oder 2	Pneumatische Ausf. Kennung N, hydraulische Ausf. Kennung ID	Kit Induktive Näherungsschalter zu montieren - Ausführung S	Mit Zentrier Ausführung BC	Mit spitzverzahnung Ausführung Code D	Version ±0.01 Code Z
Type	Version 1 ou 2	Indiquer pour pneumatique PN et hydraulique ID	Kit pour monter des détecteurs - signaler S	Pour centrage signaler code BC	Morses striées code D	Version ±0.01 Code Z
CFB 160	C1	PN	S	BC	D	Z